

Features

- Case includes 24 Urinal Balls.
- Balls are individually packaged in recycled materials that allow for easy maintenance.
- Organic bacteria released during use designed to enhance product maintenance and encourages optimal performance.
- To be added to routine Waterless Urinal maintenance schedule; follow manufacturers waterless urinal maintenance schedule.
- Lightly scented to enhance restroom experience.
- Spherical shape to not cause splashing during use; unlike traditional pucks.
- Ball to be placed on top of urinal strainer and should not be deposited in the urinal drain during maintenance.
- Waterless Urinal maintenance ball is designed to change color after approximately two weeks of use; this will provide a visual indicator it is time to maintain the Waterless Urinal to allow for optimal performance.
- Note: This product is not available for shipping to HI.



Codes/Standards

None Applicable

KOHLER® One-Year Limited Warranty

See website for detailed warranty information.

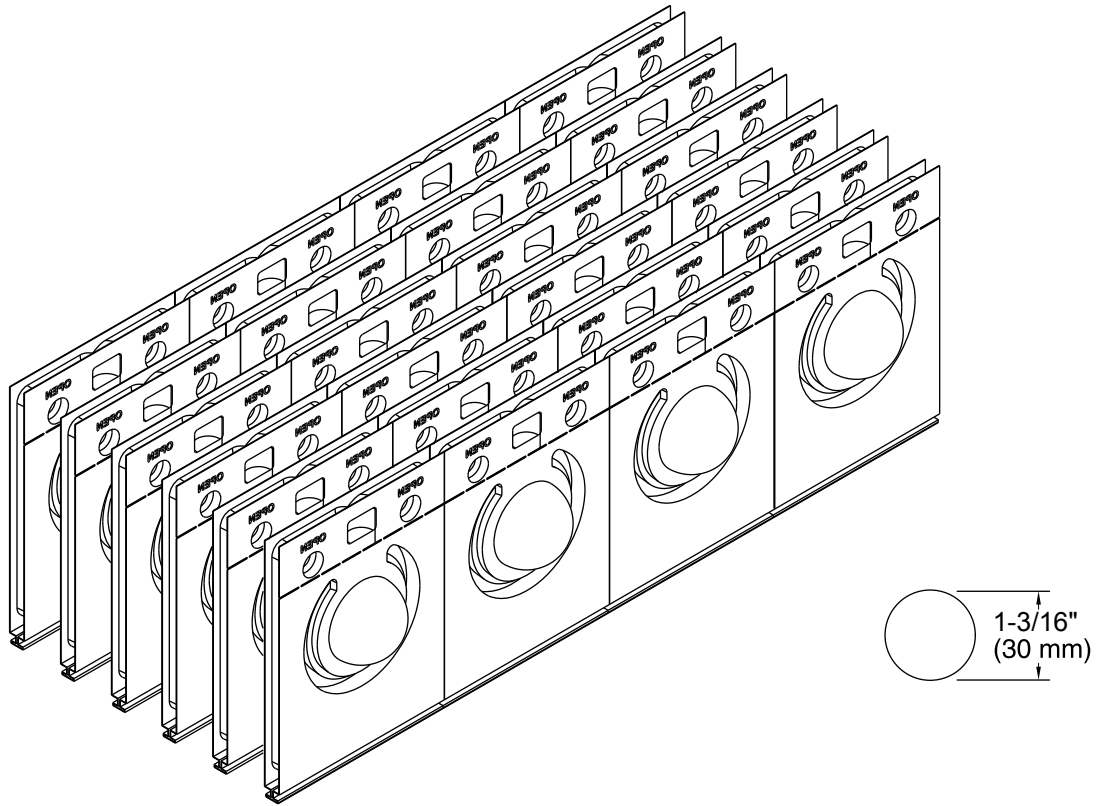

Technical Information

All product dimensions are nominal.